



HR-20

CE Approved:
MD, EMC, LVD

Category 4, EN 954-1
Type III C, EN 574

- Self retaining function
- Safety category 4 / Type IIIC
- Short circuit protection via PTC-fuse
- Detachable terminals
- External voltage supply for Duelco hand sensor actuator TST-2

Function:

Two hand control relay for dangerous work processes such as punching or pressing. Equipped with LEDs for status indication of the push buttons. Can be used in applications with a self retaining function.

Technical facilities regarding safety requirements:

- Forced contacts
- Two-pole input terminals for activation contacts, monitored for short circuit by PTC-fuse
- Two channel self retaining function for output contacts
- Short circuit protected transformer in the 230 V AC version

Approvals:



● Approved

User's advantages:

- 2 NO safety outputs
- 1 NC signal output
- Contact load: AC 3 A / DC 3 A
- Monitoring of external contacts
- Possibility for connection of doormat / photoswitch
- LED indication of input and output status
- External voltage supply for Duelco hand sensor actuator, TST-2
- Detachable terminals
- DIN rail mount
- Design is based on the European Standard, EN 60204-1 / EN 574
- Complies with MD, EMC, LVD (98/37/EC, 92/31/EEC and 73/23/EEC)
- EU type-examination at SAQ, Sweden

➔ **Technical specifications and physical dimensions, see page 44-45**

Block diagram:

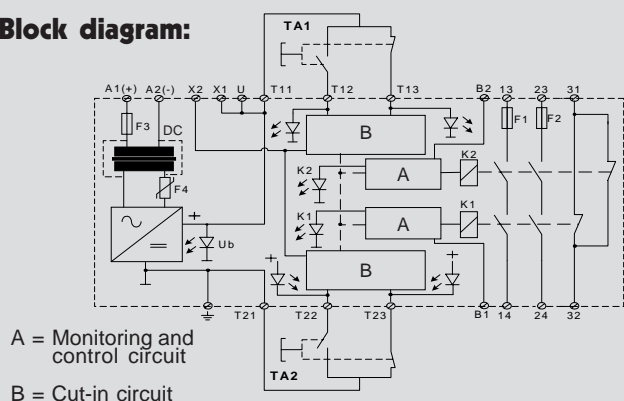

Front layout:

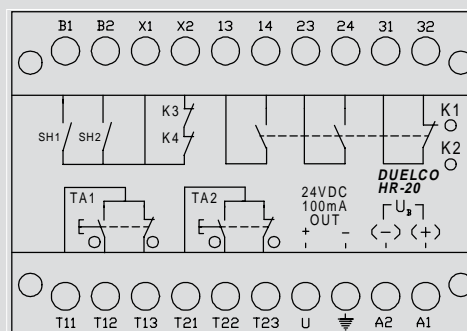

Terminal description:

- A1/A2:** Power supply (+) / Power supply (-)
T11: TA1 button (common)
T12/T13: TA1 NO input / TA1 NC input
T21: TA2 button (common)
T22/T23: TA2 NO input / TA2 NC input
X1: + output for external monitoring
X2: + input for external monitoring
B1/B2: Input for self retaining K1 / Input for self retaining K2
13-14, 23-24: NO safety output contacts
31-32: NC signal output contact
U: +24V output (for TST-2)
Earth: Earth

Order information

Article name	Article no.
HR-20, 24 V DC	42200241
HR-20, 24 V AC	42200240
HR-20, 120 V AC	42201200
HR-20, 230 V AC	42202300

Terminal description, Duelco hand sensor actuator TST-2:

- 1: Common connection
- 2: NO contact
- 3: NC contact
- 4: Power supply A1 (+)
- 5: Power supply A2 (-)

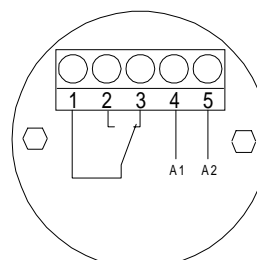

Operation description and connection examples

Operating voltage must be connected to the terminals A1(+) and A2(-). With terminals X1 and X2 short-circuited, the monitoring and control circuit will be activated. In this condition the output contacts 13-14 and 23-24 are open and 31-32 is closed.

After operation of the two contact sets TA1 and TA2 (see "Requirements for the contacts" and page 35) - each consisting of one set of forced make and break contacts in channel 1 (T11, T12, T13) and channel 2 (T21, T22, T23), HR-20 activates. I.e. the current paths 13-14 and 23-24 are closed while 31-32 is open.

The LEDs at the terminals T12, T22 and at the relays K1 and K2 illuminate. The time period between operation of TA1 and TA2 is max. 500 ms. This period is a requirement of the present standards.

Contact sets TA1 and TA2 ensure that faults such as a welded contact or a short circuit in or between contact sets, will be registered by the monitoring circuit. This makes restart impossible

until the fault is rectified and the two hand relay HR-20 is back in its dwell position.

Requirements for the contacts:

The contacts for the inputs TA1 and TA2 can be of the capacitive type, like Duelco's TST-2 or of the mechanical type with one forced and one break contact function which are physically independent of each other (see connecting examples).

The forcing and the breaking contact function must function parallel and must not be mutually forced.

NOTE!

Use of any such mutually forced switch can possibly - due to a welded contact - lead to a situation where the HR-20 will not receive a stop signal even though the actuator has been deactivated. The described occurrence is only possible, if the defective actuator is released first!

1 General application

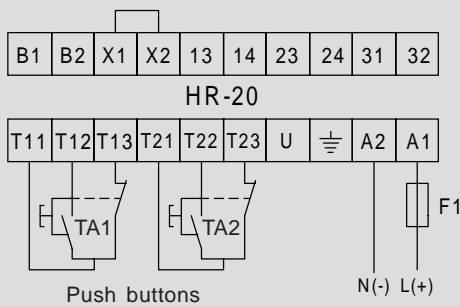

2 Connection of extension contact block EU-10

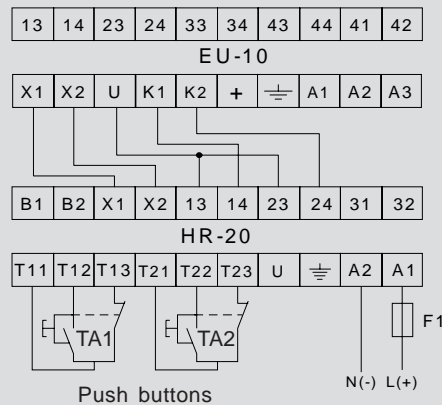

3 Self retaining function

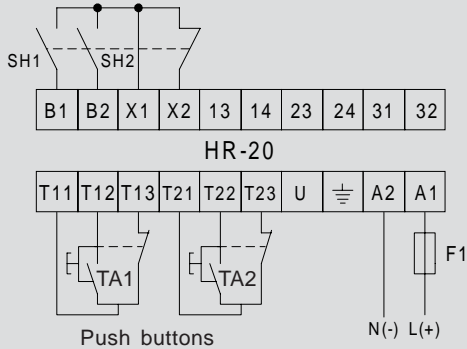

4 Connection of external contacts

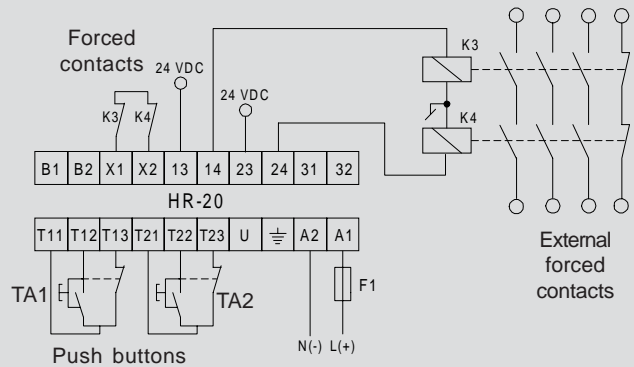

5 Connection of hand sensor actuator TST-2

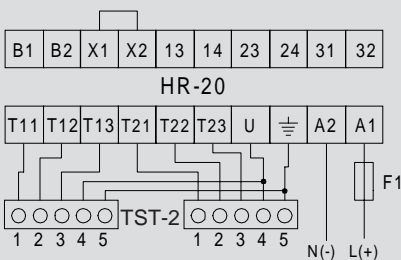

6 Connection of safety mat

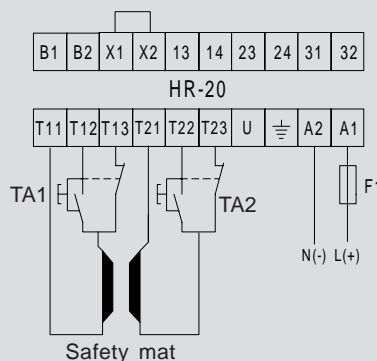

7 Connection of light-admitting curtain

